



RADE KONČAR KONTAKTORI I RELEI D.O.O.

1000 - Skopje, Macedonia, III Makedonska brigada br.54

Tel./Fax++389 (0)2/ 2461-106; 2465-586; 2464-167

E-mail: export@radekoncar.com.mk;

http: //www.radekoncar.com.mk

CONTACTORS

CNM 140,CNM 170

MOUNTING OF THE ADDITIONAL AUXILIARY CONTACT BLOCK VERSION CNM 140/170 44

1. Remove the screws M3.5x18 and release the auxiliary contact blocks (pos.1 pic. 1)
2. Broke the plastic window (pos.2 pic. 1)
3. Assemble a block from the auxiliary contact blocks (pos.2,3 pic. 2) and the additional auxiliary contact blocks pos. 4,5 pic. 2) using the screws M3.5x30 (pos. 6 pic.2)
4. Remove the arc chamber by pushing down and rotating the screws by 90° (pos. 7.1 pic. 2)
5. Push down the contactor's carrier and position the assembled block into the hole in a way that it matches the contactor's carrier
6. Attach the assembled block using the screws M3.5x30
7. Put back the arc chamber and lock it by pushing down and rotating the screws by 90°

Note: The assembled block A formed by the auxiliary contact block marked as 14 22 21 13 and the additional auxiliary contact block marked as 54 62 61 53 should be mounted on the contactor's left and the assembled block B formed by the auxiliary contact block marked as 44 32 31 43 and the additional auxiliary contacts block marked as 84 72 71 83 should be mounted on the contactor's right side.

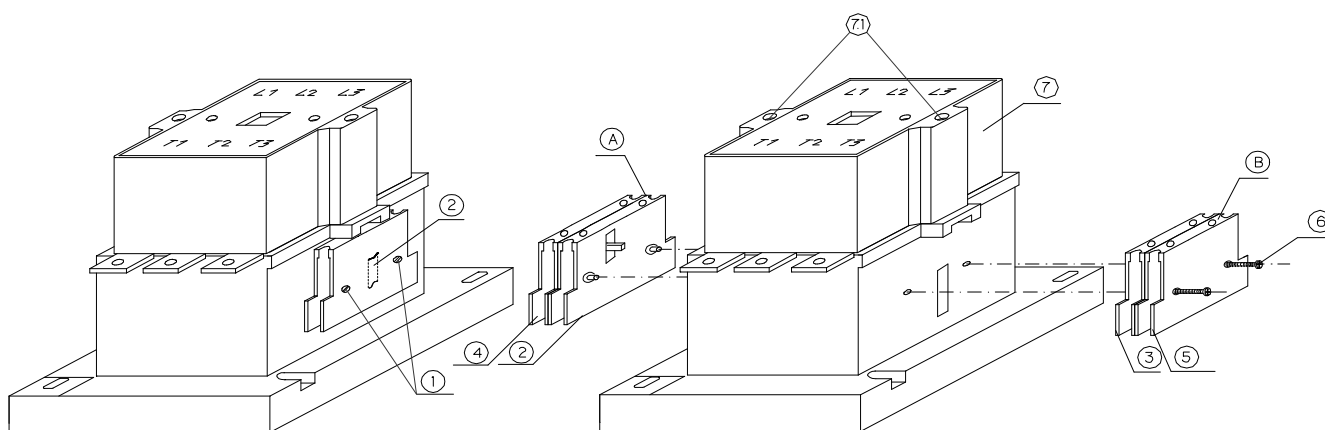

Pic.1

Pic.2