



R.KONČAR KONTAKTORI I RELEI D.O.O.

INSTRUCTIONS FOR USE AND MAINTENANCE
УПАТСТВО ЗА УПОТРЕБА И ОДРЖУВАЊЕ
UPUSTVO ZA UPOTREBU I ODRŽAVANJE

CNN 9 0022, CNN 9 004, CNN 12 0022, CNN 12 004
IEC 60947-1, IEC 60947-5

Dimension drawing / Димензиски скици / Merne skice

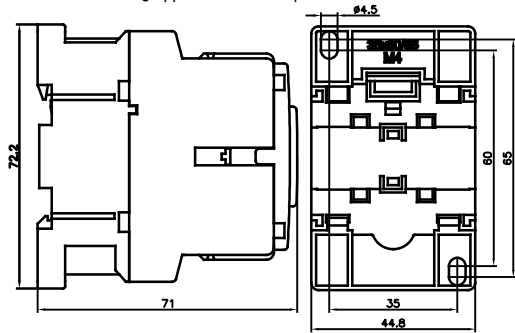

CNN 9, CNN 12, CNN 18, CNN 22, CNN 25, CNN 30

Mounting on rail 35mm (DIN 50022) / Монтирање на шина 35мм / Montaža na šinu 35mm

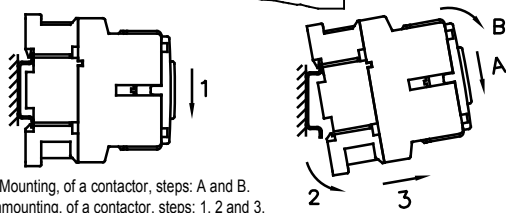
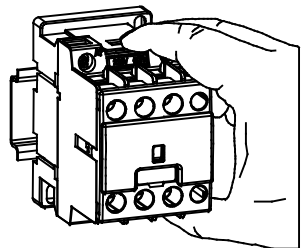

Mounting, of a contactor, steps: A and B.
Unmounting, of a contactor, steps: 1, 2 and 3.

Монтирање на контактор, чекор: А и Б
Демонтирање на контактор, чекор 1, 2 и 3

Montaža kontaktora, korak: A i B
Demontaža kontaktora, korak: 1, 2 i 3

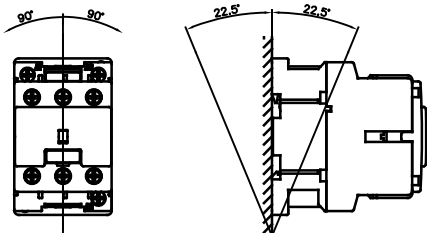

Possible installation positions / Можни инсталациони позиции / Mogući položaj instalacije

Connection diagrams and terminal markings

AC coil operation

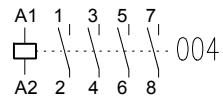
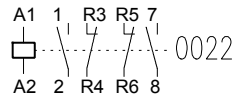

Replacement of the coil
Замена на калем
Zamena kalema

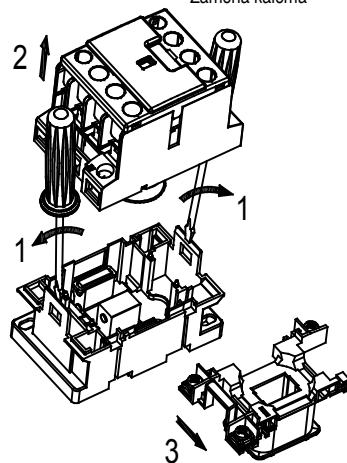

Conductor cross section / Пресек на проводник
Presek provodnika

Solid		1.5-4	mm ²
		1.5-4	
		1.5-4	
Fine Wire		1-4	mm ²
		1-4	
		1-4	



R.KONČAR KONTAKTORI I RELEI D.O.O.

INSTRUCTIONS FOR USE AND MAINTENANCE
УПАТСТВО ЗА УПОТРЕБА И ОДРЖУВАЊЕ
UPUSTVO ZA UPOTREBU I ODRŽAVANJE

CNN 9 0022, CNN 9 004, CNN 12 0022, CNN 12 004
IEC 60947-1, IEC 60947-5

Dimension drawing / Димензиски скици / Merne skice

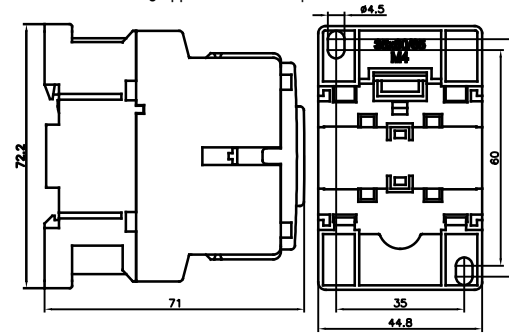

CNN 9, CNN 12, CNN 18, CNN 22, CNN 25, CNN 30

Mounting on rail 35mm (DIN 50022) / Монтирање на шина 35мм / Montaža na šinu 35mm

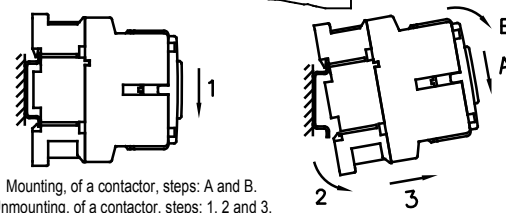
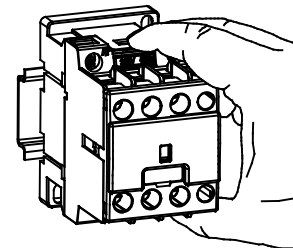

Mounting, of a contactor, steps: A and B.
Unmounting, of a contactor, steps: 1, 2 and 3.

Монтирање на контактор, чекор: А и Б
Демонтирање на контактор, чекор 1, 2 и 3

Montaža kontaktora, korak: A i B
Demontaža kontaktora, korak: 1, 2 i 3

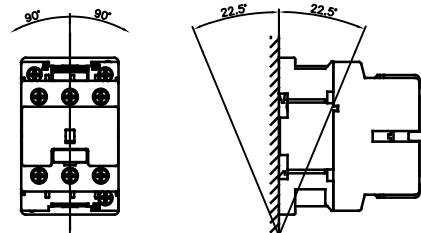

Possible installation positions / Можни инсталациони позиции / Mogući položaj instalacije

Connection diagrams and terminal markings

AC coil operation

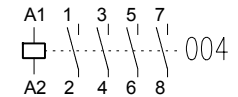
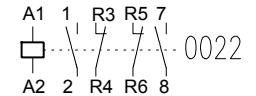

Replacement of the coil
Замена на калем
Zamena kalema

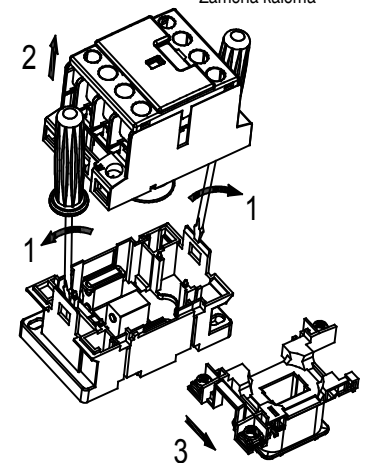

Conductor cross section / Пресек на проводник
Presek provodnika

Solid		1.5-4	mm ²
		1.5-4	
		1.5-4	
Fine Wire		1-4	mm ²
		1-4	
		1-4	

Mounting auxiliary blocks BP2 and BP4 / Монтирање помошни блокови БП2 и БП4 / Montaža pomožnih blokova BP2 i BP4

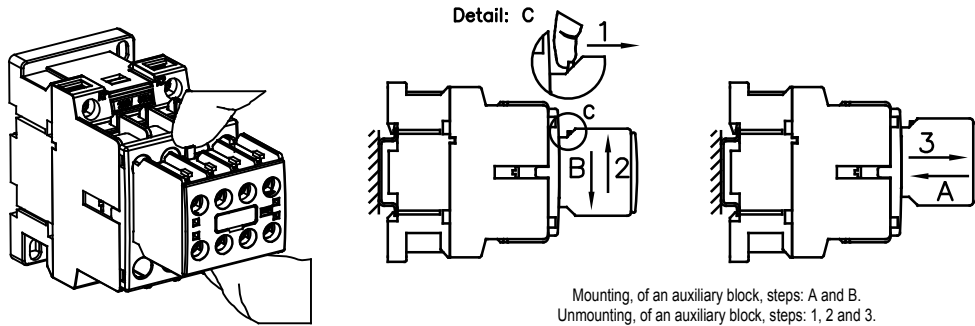

Mounting, of an auxiliary block, steps: A and B.
Unmounting, of an auxiliary block, steps: 1, 2 and 3.

Монтирање на помошен блок, чекор: А и Б
Демонтирање на помошен блок, чекор 1, 2 и 3

Montaža pomožni blok, korak: A i B
Demontaža pomožni blok, korak: 1, 2 i 3

Mounting auxiliary block BP3
Монтирање помошен блок БП3
Montaža pomožni blok BP3

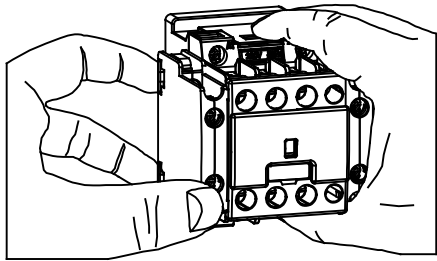

Mounting step A Mounting step A1

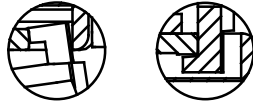

Mounting step B Mounting step B1 Mounting step C

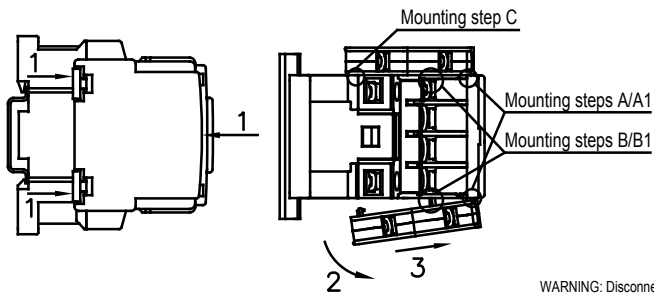
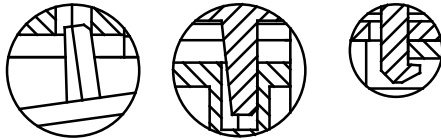

Mounting, of an auxiliary block, steps:
- First put the block in position A/A1 and B/B1, second push the block in position C
Unmounting, of an auxiliary block, steps:
- First put the hand on the block like it is shown on the picture. After with the two fingers push it up the block - position 1, rotate the block - position 2 and position 3 take off the block.

WARNING: Disconnect power from source before installing, modifying or servicing.
ПРЕДУПРЕДУВАЊЕ: Исклучи го напојувањето пред инсталација, менување или сервисирање
UPOZORENJE: Isključiti napajanje izvora pre instalacije, modifikovanje ili servisiranje

RK R.KONČAR KONTAKTORI I RELEI D.O.O.



RECYCLABLE

Mounting auxiliary blocks BP2 and BP4 / Монтирање помошни блокови БП2 и БП4 / Montaža pomožnih blokova BP2 i BP4

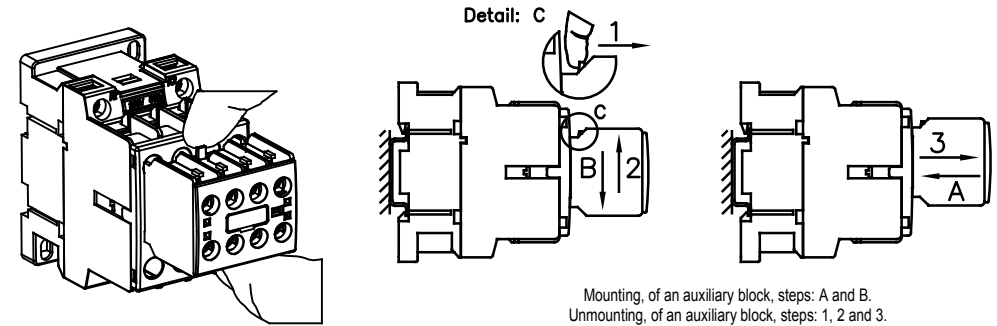

Mounting, of an auxiliary block, steps: A and B.
Unmounting, of an auxiliary block, steps: 1, 2 and 3.

Монтирање на помошен блок, чекор: А и Б
Демонтирање на помошен блок, чекор 1, 2 и 3

Montaža pomožni blok, korak: A i B
Demontaža pomožni blok, korak: 1, 2 i 3

Mounting auxiliary block BP3
Монтирање помошен блок БП3
Montaža pomožni blok BP3

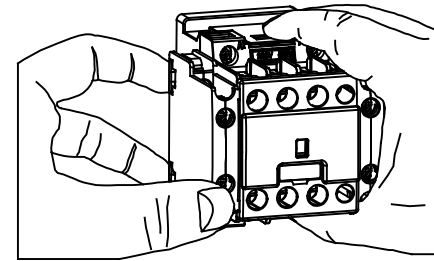

Mounting step A Mounting step A1

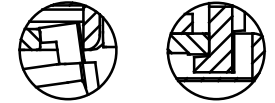

Mounting step B Mounting step B1 Mounting step C

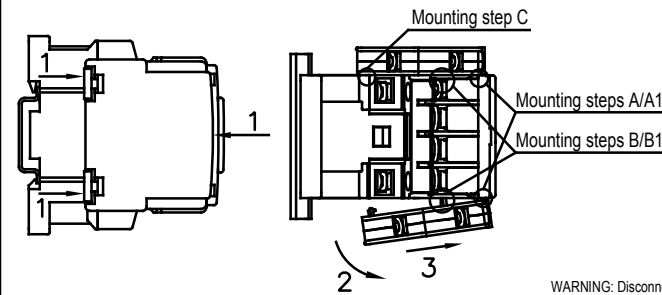
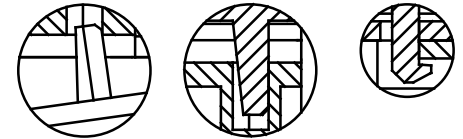

Mounting, of an auxiliary block, steps:
- First put the block in position A/A1 and B/B1, second push the block in position C
Unmounting, of an auxiliary block, steps:
- First put the hand on the block like it is shown on the picture. After with the two fingers push it up the block - position 1, rotate the block - position 2 and position 3 take off the block.

WARNING: Disconnect power from source before installing, modifying or servicing.
ПРЕДУПРЕДУВАЊЕ: Исклучи го напојувањето пред инсталација, менување или сервисирање
UPOZORENJE: Isključiti napajanje izvora pre instalacije, modifikovanje ili servisiranje

RK R.KONČAR KONTAKTORI I RELEI D.O.O.



RECYCLABLE